

EIXO/SHAFT	
PADRÃO/STANDARD	X
OPCIONAL/OPTIONAL	
ESPECIAL/SPECIAL	

Dimensões em polegada
Dimensions in inches

CERTIFIED WEG MOTORES
Certified document.
Not subject to changes.

THIS IS AN UPDATED REVISION, THE PREVIOUS ONE MUST BE DISREGARDED.

A
B
C
D
E

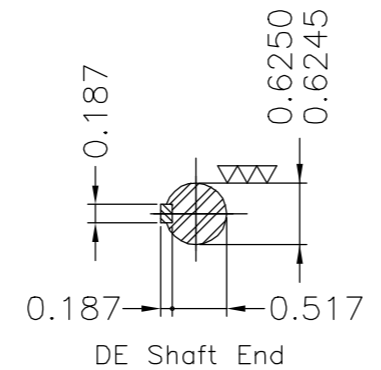
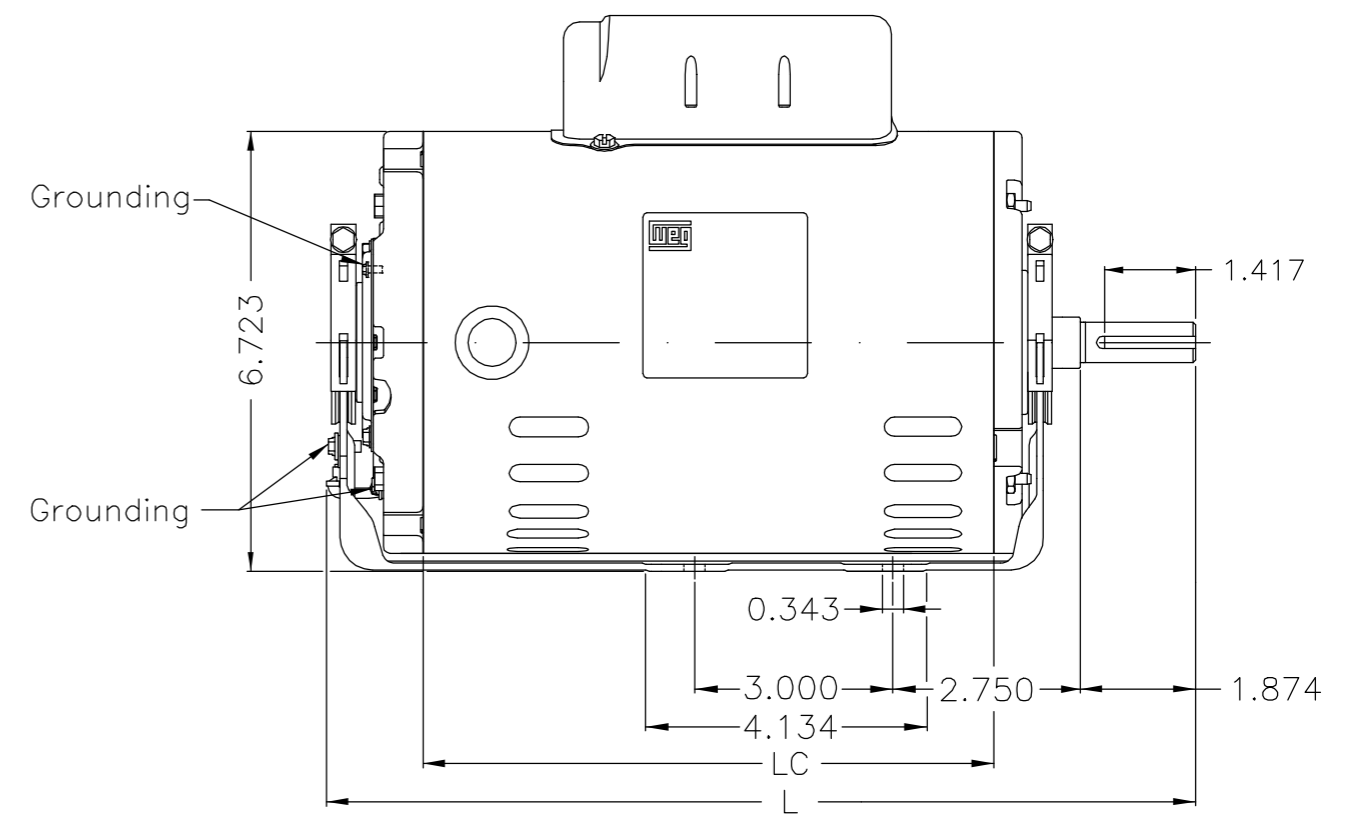
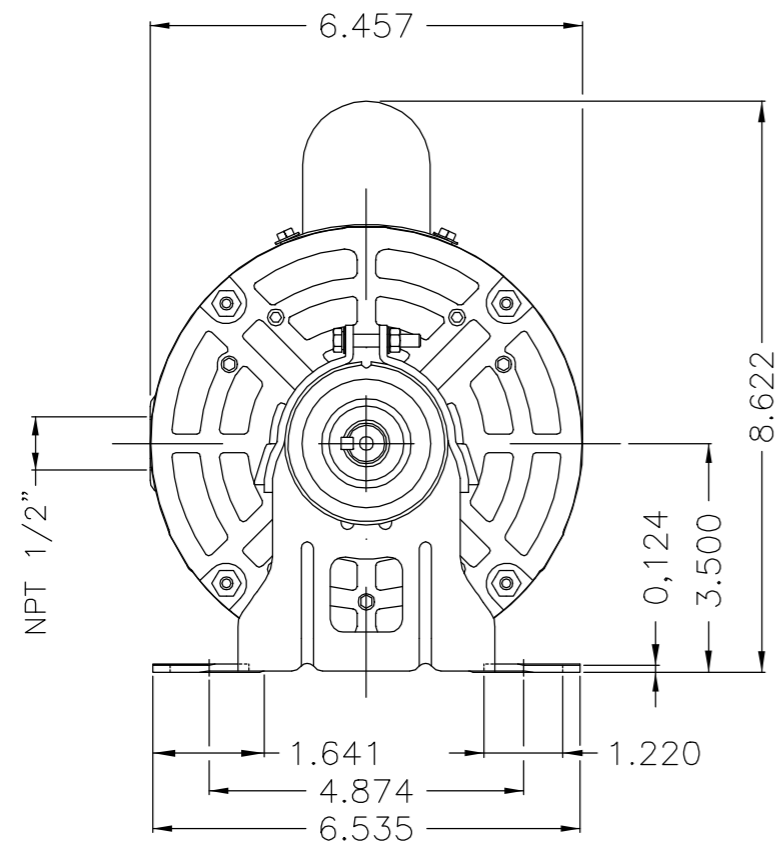

Protetor térmico fenólico - automático / Phenolic thermal protector - automatic

Forma construtiva B3D / Mounting F-1/B3R(D)

WEG ELECTRIC CORPORATION - WEC

500001884523	Alterado conforme ZM 415176978	DEYKSON	SANDRIN	SANDRIN	08.02.2021	03
500001576926	ALTERADO CONFORME ECM	RLEMOS	ARIVABENE	ARIVABENE	01.04.2019	02
ECM	LOC	SUMMARY OF MODIFICATIONS	EXECUTED	CHECKED	RELEASED	DATE VER
EXECUTED	LUCASSZ	SINGLE PHASE ODP ROLLED STEEL FRAME 56 ODP	10004291054			
CHECKED	VICTORCM		000	03		
RELEASED	VICTORCM					
REL DT	19.05.2016	WMO	LINHARES	ENGENHARIA DO PRODUTO	SHEET	1 / 2

				L	LC	
0.75 HP	04 Poles	60Hz	414286906	12.008	7.480	C
1.00 HP	04 Poles	60Hz	414285954	12.409	7.874	B
0.75 HP	04 Poles	60Hz	414285631	12.008	7.480	A

UNCONTROLLED COPY

RELEASED

ZME A3